

# Motion Sensor User Guide



- Dual PIR beams for minimal false alarms
- Built-in 95-decibel adjustable siren
- 1km wireless range
- Built-in repeater functionality for extended wireless range
- Two-way wireless communication – 868 MHz frequency
- Fully adjustable sensitivity settings
- Up to 18m detection range, 90 degrees wide
- Operates up to 3 years from standard AA alkaline batteries
- Theft protection: Any change in the orientation will trigger the built-in Siren, whether the system is Armed or Disarmed
- Active Infrared detects masking attempts in the near-field vision. A masking attempt will send a notification to the user and trigger the built-in Siren

## Index

1	Overview of the Kwêbeam sensor.....	3
1.1	Detection Pattern .....	3
2	Installing the sensor.....	4
2.1	Identify best installation position for sensors.....	4
2.2	Mounting the sensor .....	5
2.3	Using the Angle bracket to mount the Beam.....	6
2.4	Detection area.....	7
2.4.1	Ground levels .....	8
2.5	Testing the sensor.....	9
2.5.1	Insert the three AA batteries .....	9
2.5.2	Add the sensor to the System .....	9
2.5.3	Do Walk Test .....	10
2.5.4	Adjust the sensitivity .....	10
2.5.5	Quick signal test .....	10
3	Motion Detection .....	11
3.1	Arm modes.....	11
3.2	Detection sequence when armed .....	11
3.3	Avoiding False alarm triggers.....	11
3.4	Obstructions causing false alarms.....	12
4	Wireless range.....	12
5	Tilt Detection.....	12
6	Anti-Masking (KB-AM version).....	13
7	Maintenance .....	13

# 1 Overview of the Kwêbeam sensor

The wireless outdoor beams feature a unique built-in siren that provides an unexpected element of surprise next to an intruder. The built-in siren can be muted or sound for a delay defined by the user.

The sensor features dual PIR detection to ignore pets & detect people. Both top & bottom detectors must sense a moving heat source for a valid alarm signal. False alarms are further reduced with software algorithms to differentiate true detection from environmental noise.

The system is completely wireless and powered by standard AA alkaline cells. All wireless beams can transmit & receive signals for reliable 2-way communication. Built-in repeater functionality strengthens wireless performance and overcomes wireless range issues.

A Tilt sensor reports orientation changes while the system is armed or disarmed. To prevent theft & vandalism the built-in siren will sound when the sensor is forcibly removed.

The Anti-Masking version includes Active Infrared sensors that detects damaged lenses or unwanted objects in front of the lens. This prevents masking attempts while the system is armed or disarmed.

## 1.1 Detection Pattern

- The KwêBeam sensors have Dual Passive Infrared motion detectors – both the top & bottom infrared beams must detect a moving heat source for a valid alarm signal.
- Top and bottom infrared beams are in parallel with the ground level, therefore the best MOUNTING HEIGHT is 0.8m – 1.2m from the ground.

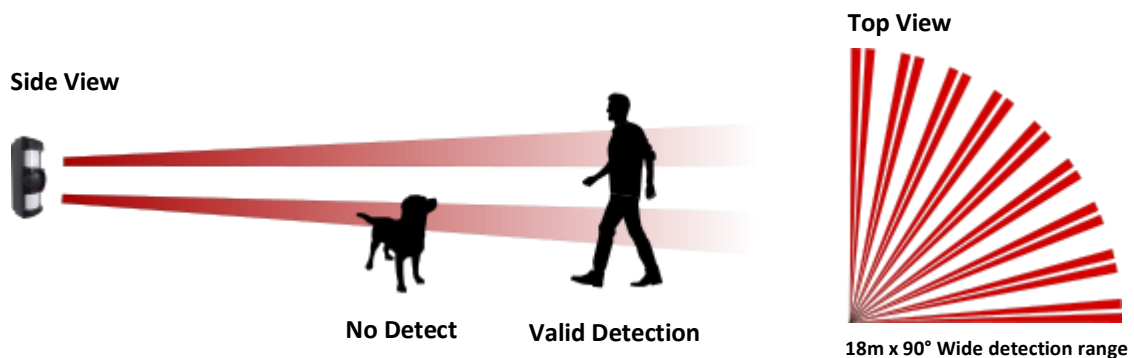

- Detection area: Up to 18 meters by 90° wide on level ground surface

## 2 Installing the sensor

### 2.1 Identify best installation position for sensors

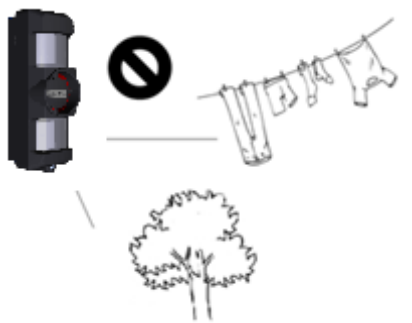
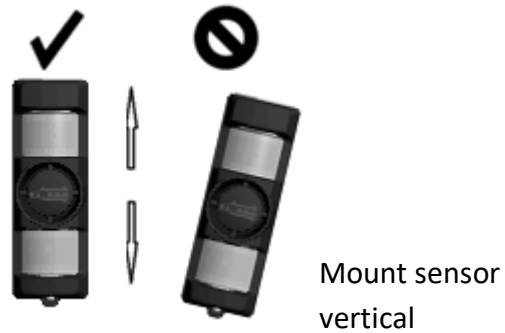

Avoid obstruction and large moving objects in front of a heat source

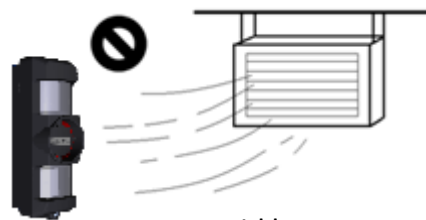

Avoid heat sources close to the sensor (warm walls and air- conditioners)

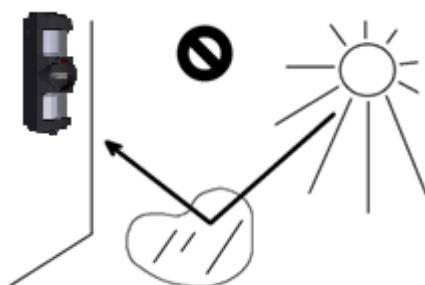

Face the sensor away from strong light & reflections.  
Note: Windows facing a road can reflect moving vehicles.

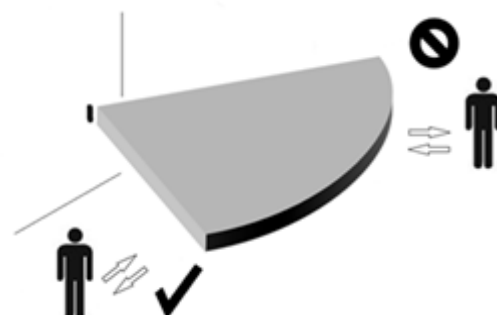

Sensor is less sensitive when moving towards it and most sensitive when crossing the detection area.

## 2.2 Mounting the sensor

Mount the Beams 0.8 – 1.2 meter from the ground level, using the supplied fasteners and optional bracket.



Do not remove the rubber sponge at the back of the sensor when mounting the sensor.



The beam detects moving heat sources, therefore it is recommended NOT to face the sensor to warm objects in close vicinity, e.g. warm walls with moving plants between the sensor & wall, reverse side of air conditioners, moving vehicles, sunlight reflections.



- Remove lock screw at the bottom of sensor



- Pull the bottom of the face cover to open



- Pull internal unit from back box
- Mark mounting holes, drill 6mm holes & secure with provided screws

### Internal Unit

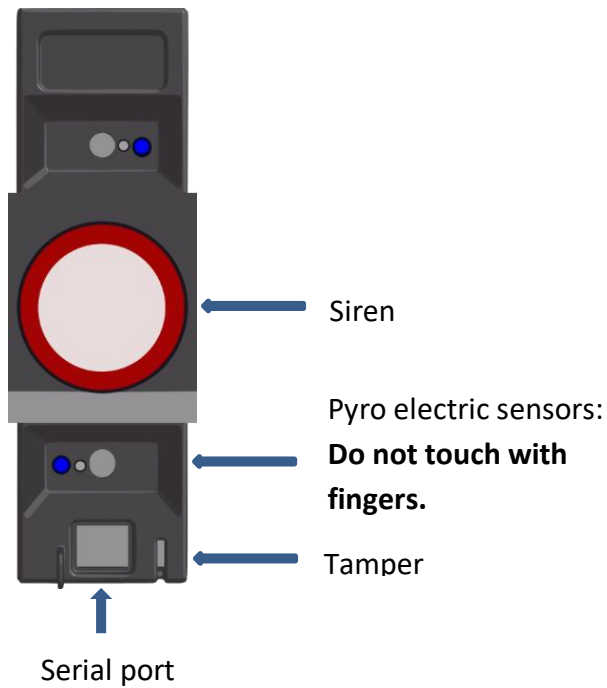

## 2.3 Using the Angle bracket to mount the Beam

KwêBeam sensors can be mounted to face different directions:

- 45° facing left or right using bracket
- 22.5° facing left or right using bracket
- 0° facing straight, no bracket

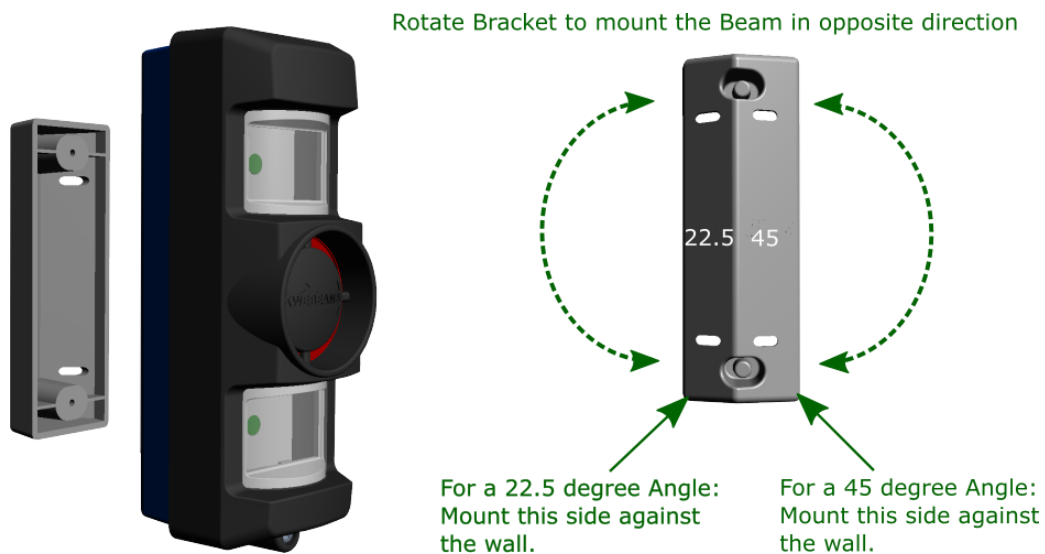

## 2.4 Detection area

45° Bracket Mount

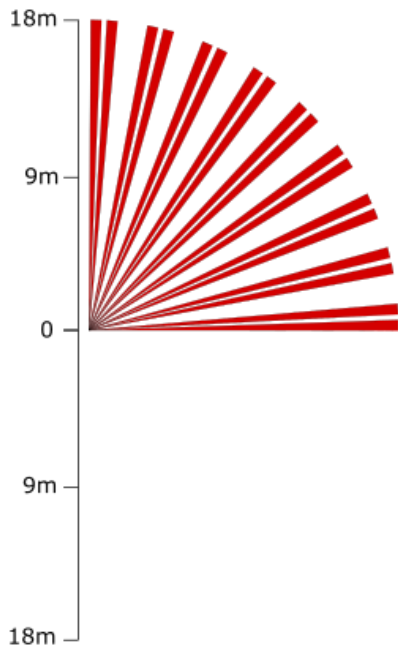

22° Bracket Mount

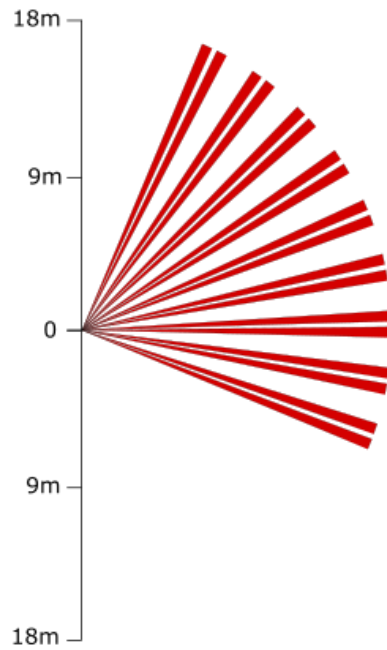

0° Mount (No Bracket)

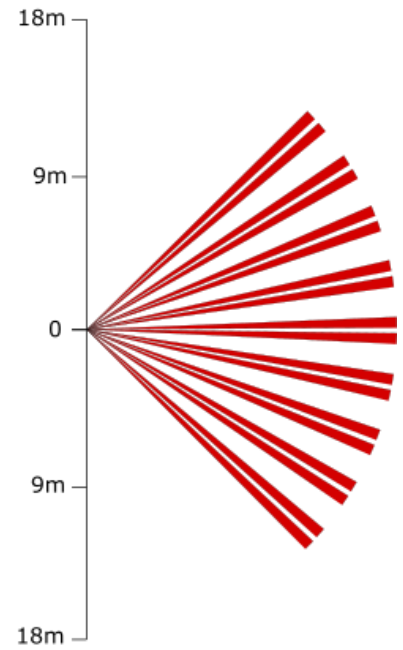

Side View

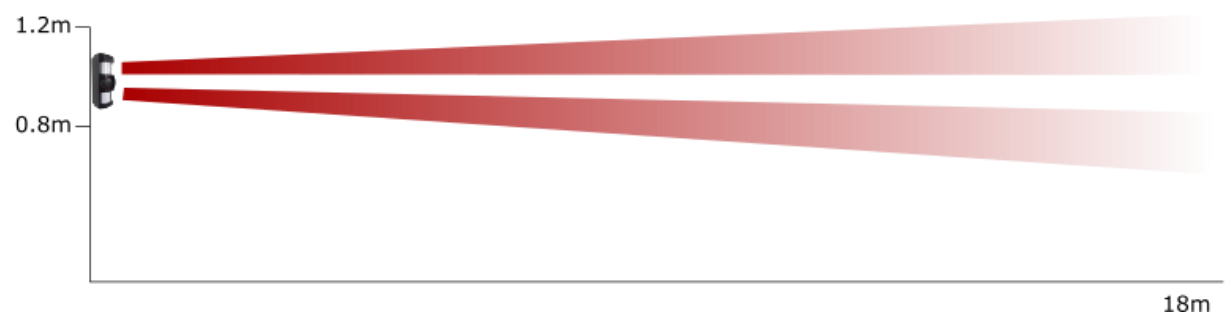

### 2.4.1 Ground levels



Best detection range when ground is level.  
Mount the beam 0.8m - 1.2m above ground level.



Short detection range & possible false alarms when ground level slopes upward.  
Note: Mount the beam higher (1.2m - 1.4m) to assist with upward slope.

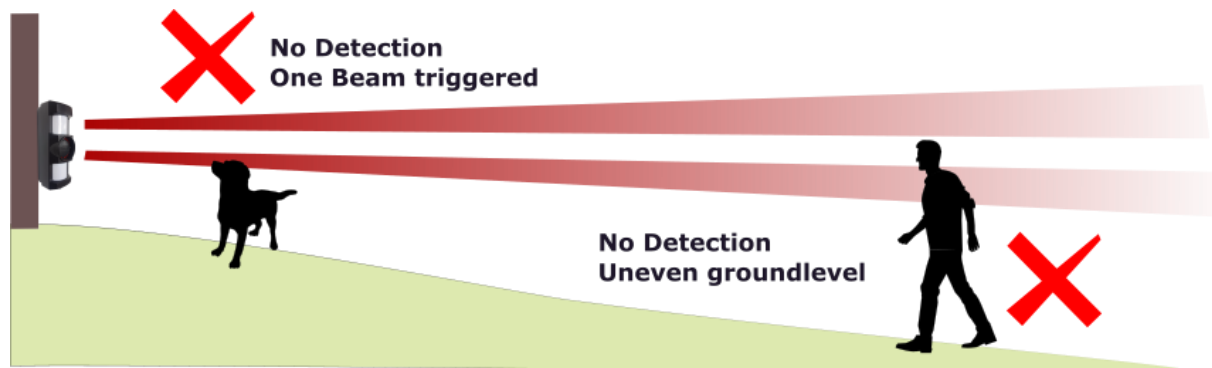

Short detection range when ground slopes downward.  
Note: Mount the beam lower (0.6m - 0.8m) to assist with downward slope.

## 2.5 Testing the sensor

### 2.5.1 Insert the three AA batteries

The siren will sound softly for approximately 2 minutes to indicate warm-up period.  
The sensor will be in functional mode when the siren is silent.

### 2.5.2 Add the sensor to the System



If the KwêHub is part of the system, it is recommended that the mobile App is used to Add the sensor.

If no Kwêhub is available, and only the keypad is part of the system, ignore this section and follow the instructions in the Keypad user manual to add the sensor.

- 1) Make sure the KwêHub is added to the App. If not, follow the KwêHub manual for details.
- 2) Open the front cover of the Sensor you want to add to the system.
- 3) Navigate to “Devices” and press the “+” button. Enter a name and zone number for the sensor.



Zone numbers can be the same for different sensors (more than one sensor can have the same zone number). When an alarm is triggered, the buzzer in the KwêHub will sound a unique sequence for each zone.

- 4) All the sensors with an open cover will start a short beeping sequence once the “Confirm” button is pressed. Before the beeping sequence ends, do one of the following with the sensor:
  - CLOSE the front cover while the sensor is beeping, OR
  - Keep the internal part of the sensor upright, then TILT the internal part while the sensor is beeping.
- 5) The sensor will now appear as a new device in the App.

### 2.5.3 Do Walk Test

The sensor will enter Walk-test-mode when closing the front cover or when Walk Test mode is activated from the APP. The sensor will beep each time motion is detected. Walk test mode will end when there is no movement in front of the sensor for 90 seconds, or the system is armed.

### 2.5.4 Adjust the sensitivity



If the KwêHub is part of the system, it is recommended that the mobile App is used to configure the sensor settings.

If no Kwêhub is available, and only the keypad is part of the system, ignore this section and follow the instructions in the Keypad user manual to adjust the settings.

To change the default detection settings from the APP, press the right arrow next to the system name. Navigate to “devices”, then press the gear icon next to the sensor name.

Detection sensitivity can be adjusted using the following settings:

- 1) Sensitivity: Default is 4. Setting 1 is most sensitive, and 8 is least sensitive.
- 2) Detection Count: The number of valid detections in quick succession before an alarm signal is sent.
- 3) Detection quality: The detection difference between the Top and Bottom eye of the sensor.



For detail description on the settings, press the info sign next to the setting name on the mobile App.

### 2.5.5 Quick signal test

When opening the front cover of the Sensor, the siren will indicate the signal strength as follows:

- 2 Beeps: Good Signal, with repeater functionality. The sensor can communicate directly the KwêHub.
- 1 Beep: Good signal, with NO repeater functionality. The sensor communicates to another device/sensor to get access to the KwêHub.
- No Sound: Poor or No signal.

## **3 Motion Detection**

### **3.1 Arm modes**

The system can be armed in two modes, Home OR Away mode. These two modes allow each sensor to behave differently for each mode.

E.g. While at home, it might be desired that only the front yard sensors are active with the built-in sirens set to sound for 10 seconds when triggered. The built-in sirens for the sensors in the back yard can be muted, or the sensors can be entirely by-passed. When not at home, all Built-in Sirens can be active except for the driveway siren.

### **3.2 Detection sequence when armed**

When a sensor detects motion, the user will be alerted, then the sensor will enter a 10 second 'no-detect' delay. Detections during this period will be ignored. After the 10 second delay, the sensor is ready for the next detection. After 3 valid detections within 10 seconds apart, the sensor will enter a 30 second 'no-detect' delay. The sensor will remain in this 'no-detect' mode until there is NO movement in front of the sensor for 30 seconds. Any movement within this period will reset the 30 second delay. After the 30 second delay, the detection sequence restarts.

### **3.3 Avoiding False alarm triggers**

The beam detects moving heat sources; therefore, it is recommended NOT to face the sensor to warm objects in close vicinity, e.g. warm walls with moving plants between the sensor & wall, reverse side of air conditioners, moving vehicles, sunlight reflections.

### 3.4 Obstructions causing false alarms

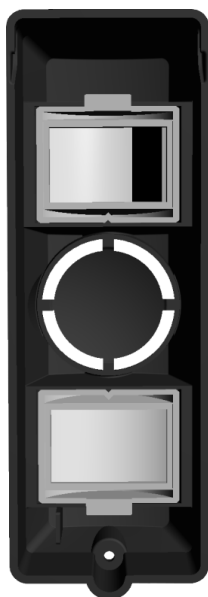

Beams can be masked when false alarms are caused by unavoidable obstructions. Tape can be used (e.g. isolation tape) to mask the area on the inner top lens. Mask the circles that points in the direction of the obstruction area.

## 4 Wireless range

In a perfect environment (Line of Sight between devices) distances up to 1000m is possible without repeater mode. The range is highly depended on the environment & will reduce dramatically with walls & structures in close vicinity. For this reason, the sensor has a Built-In repeater functionality to overcome range issues in highly dense building environments. All devices within range of the Base Unit, will automatically function as a repeater station to support devices not in range of the Base Unit.

## 5 Tilt Detection

A tilt sensor detects orientation changes in any direction. When the beam is tilted a Trouble signal will be reported & the siren will sound for two seconds. Tilt detection is useful to prevent theft of the sensor.



The Orientation sensor is disabled when the front cover of the sensor is open. After closing the front cover orientation detection will be active.

## 6 Anti-Masking (KB-AM version)

Active Infrared detects damaged lenses or unwanted objects in front of the lens causing improper sensor functionality.

The sensor will enter an Anti-Masking learning period for approx. 2 minutes after the front cover is closed (walk test mode will continue uninterrupted). Make sure no obstructions are within 30 cm from the front of the sensor during the learning period.

After the learning period, the Anti-Masking feature will function as follow:

- **When the System is Armed:** The Beam reports a trouble signal within 1 minute when masked and the built-in siren will sound.
- **When the System is Dis-Armed:** The Beam reports a trouble signal within 3 minutes when masked and the built-in siren will sound.



Sudden heavy rain can sometime cause the anti-masking to trip when the sensitivity is high. If this is undesirable, adjust the sensitivity from the App.

## 7 Maintenance

Always use **3 NEW** Energizer alkaline batteries of the same kind when replacing the batteries.



Energizer batteries are preferred as they will not leak over time.

Regularly open the front face cover & check for any signs of insects. Place a mothball behind the inner part of the sensor to keep insects out.